

SECTION A-A

SECTION B-B

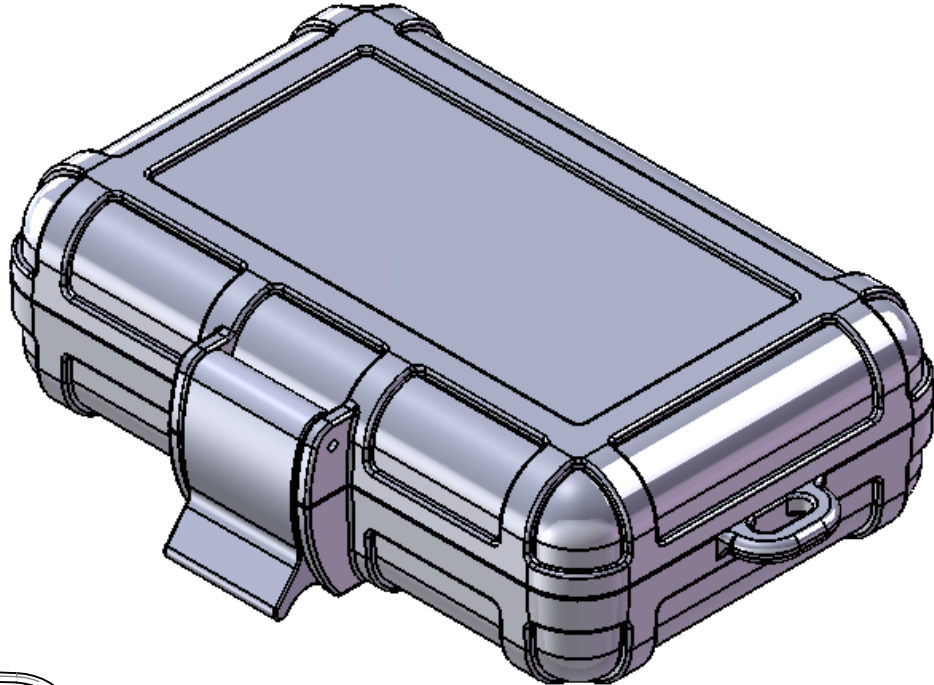

UNLESS OTHERWISE SPECIFIED DIMENSIONS ARE IN INCHES				NAME	DATE	
Sheet Metal Tolerances Angular: ± 1° Edge to Edge: ± .01 Hole Size: ± .003 Hole to Hole OR Edge: ± .005 Hole to Bend: ± .01 Bend to Edge: ± .01 Bend to Bend: ± .02 Self Clinching Components Use Hole Tolerances. & Add: ± .01 All dims. are Outside unless specified.	Machined Tolerances Angular: ± .5° Fractional: ± 1/32 Two Place Decimal: ± .010" Three Place Decimal: ± .005" Four Place Decimal: ± .001"	DRAWN	SD&D	05/14/12	S3 CASES, LLC 4014 S. LeMAY AVE. #25 FORT COLLINS, CO 80525	
		CHECKED				TITLE: T1000 Assembly
		REVIEW				
		PROPRIETARY AND CONFIDENTIAL The information contained in this drawing is the sole property of S.D. & D. Any reproduction in part or as a whole without the written permission of S.D. & D. is prohibited.		Break or Deburr all sharp edges and corners		APPROVAL
		MATERIAL		COMMENTS		
		FINISH		SIMILAR TO		
			SIZE	DWG. NO.	REV	
			B			
			Scale: 1:1		Sheet 1 of 1	

.016, (SEAL CRUSH ALLOWANCE)