

8 7 6 5 4 3 2 1

D

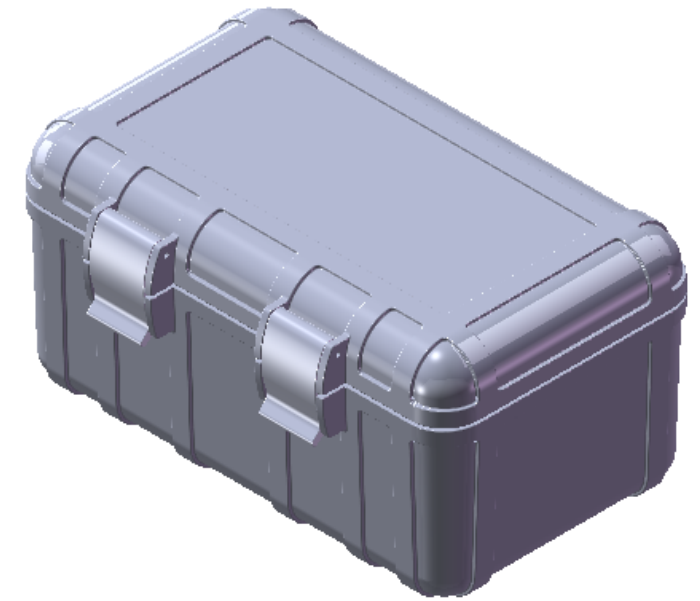
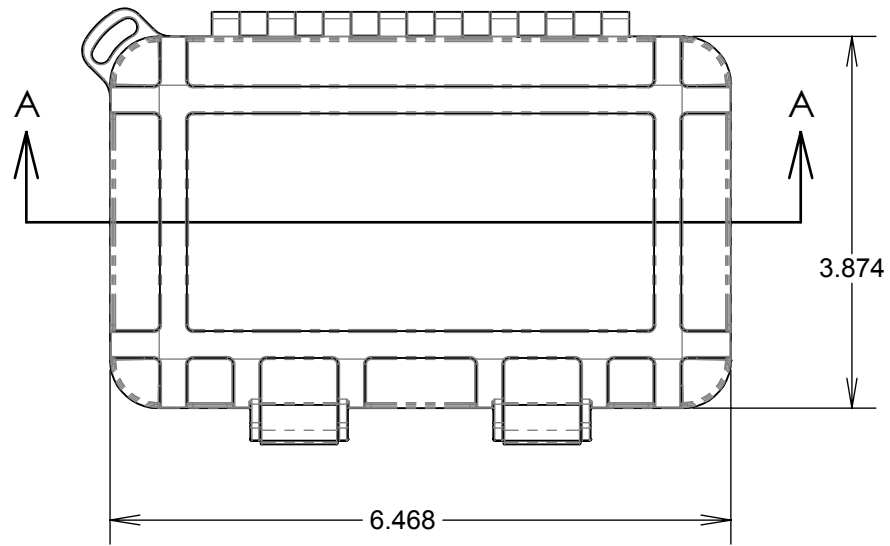
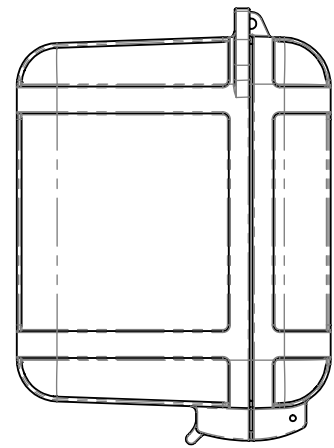

C

(GASKET CRUSH ALLOWANCE) .030

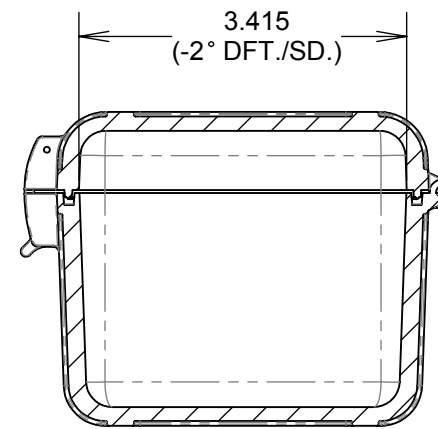
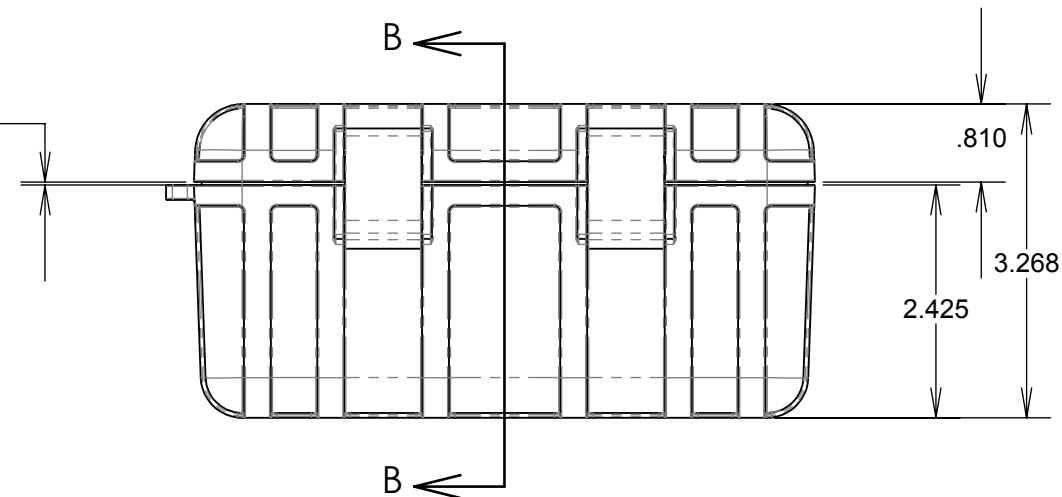

SECTION B-B

B

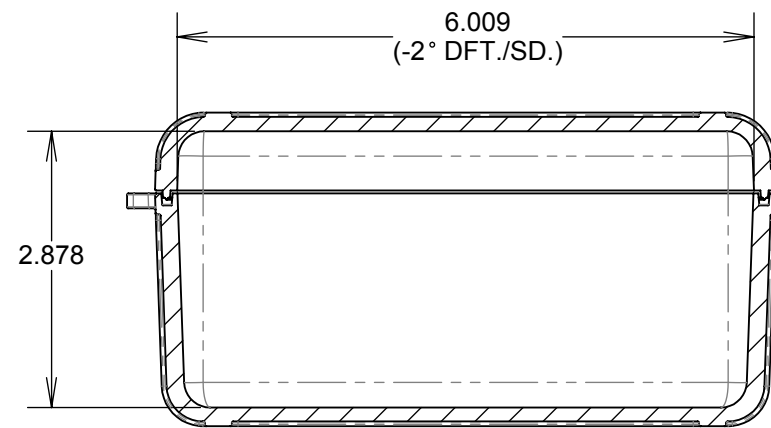

SECTION A-A

NOTES:
1.

UNLESS OTHERWISE SPECIFIED DIMENSIONS ARE IN INCHES				NAME	DATE	
Sheet Metal Tolerances Angular: ± 1° Edge to Edge: ± .01 Hole Size: ± .003 Hole to Hole OR Edge: ± .005 Hole to Bend: ± .01 Bend to Edge: ± .01 Bend to Bend: ± .02	Machined Tolerances Angular: ± .5° Fractional: ± 1/32 Two Place Decimal: ± .010" Three Place Decimal: ± .005" Four Place Decimal: ± .001"	DRAWN		S3 CASES, LLC 4014 S. LeMAY AVE. #25 FORT COLLINS, CO 80525		
		CHECKED				
REVIEW		TITLE:	T2500 Case Assembly			
APPROVAL		COMMENTS				
Self Clinching Components Use Hole Tolerances. & Add: ± .01 All dims. are Outside unless specified.	Break or Deburr all sharp edges and corners	MATERIAL		SIZE B	DWG. NO.	REV
PROPRIETARY AND CONFIDENTIAL The information contained in this drawing is the sole property of S.D. & D. Any reproduction in part or as a whole without the written permission of S.D. & D. is prohibited.	FINISH	SIMILAR TO		Scale: 1:2	Sheet 1 of 1	

8 7 6 5 4 3 2 1

A

A