

8 7 6 5 4 3 2 1

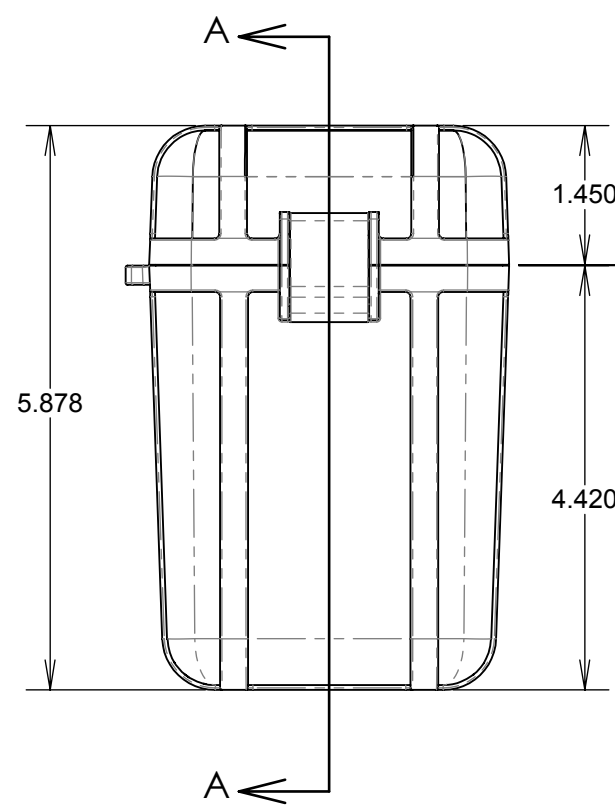

.008  
(SEAL CRUSH ALLOWANCE)

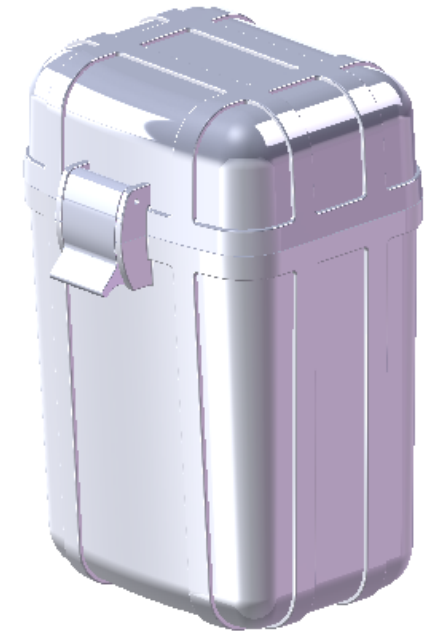
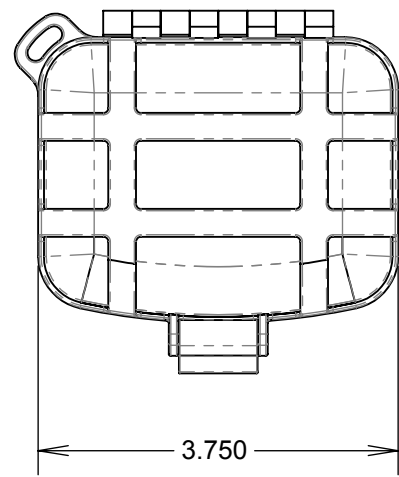
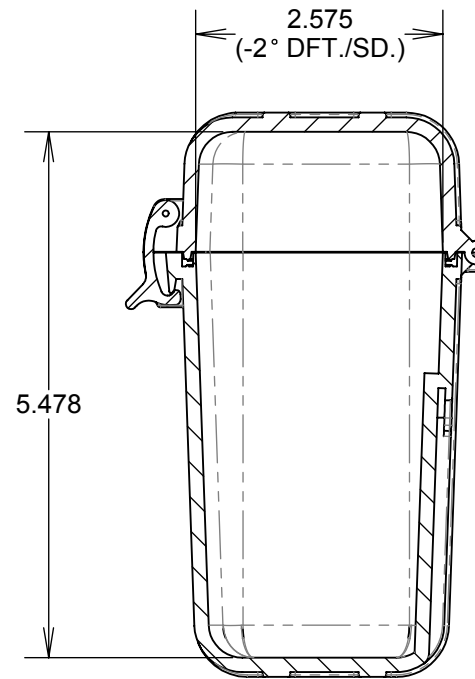
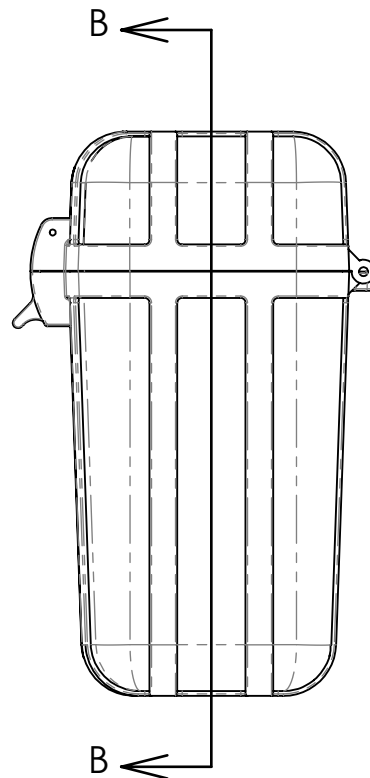

SECTION A-A

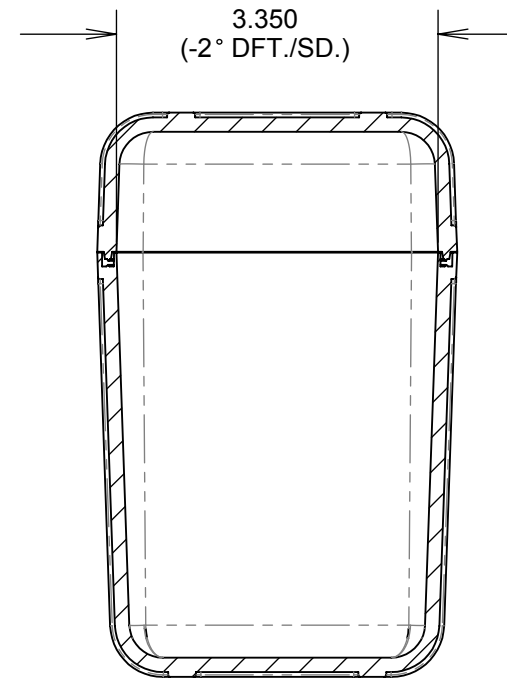

SECTION B-B

NOTES:  
1. DRAWING IS FOR REFERENCE ONLY.

UNLESS OTHERWISE SPECIFIED DIMENSIONS ARE IN INCHES		NAME	DATE	S3 Cases, LLC 4014 S. LeMay Ave. #25 Fort Collins, CO 80525	
<b>Sheet Metal Tolerances</b> Angular: ± 1° Edge to Edge: ± .01 Hole Size: ± .003 Hole to Hole OR Edge: ± .005 Hole to Bend: ± .01 Bend to Edge: ± .01 Bend to Bend: ± .02 <b>Self Clinching Components</b> Use Hole Tolerances. & Add: ± .01 All dims. are Outside unless specified.		DRAWN	S.D. & D.		
<b>Machined Tolerances</b> Angular: ± .5° Fractional: ± 1/32 Two Place Decimal: ± .010" Three Place Decimal: ± .005" Four Place Decimal: ± .001"		CHECKED			
<b>PROPRIETARY AND CONFIDENTIAL</b> The information contained in this drawing is the sole property of S3 Cases, LLC. Any reproduction in part or as a whole without the written permission of S3 Cases, LLC is prohibited.		REVIEW			
		APPROVAL			
		COMMENTS			
MATERIAL		SIMILAR TO		SIZE <b>B</b> DWG. NO. REV	
FINISH				Scale: 1:2 Sheet 1 of 1	

8 7 6 5 4 3 2 1

A

A